

HOW TO READ PRODUCT "SKU" :

FIRST TWO LETTERS
REPRESENT
"PRODUCT TYPE"

NUMBERS REPRESENT
"MODULE DIMS AND SPACING IN INCHES"
(EXAMPLE: 412 = 4" SECTION WITH 1/2" SPACE [3-1/2" BLADE])

GL-412

"SKU" ABBREVIATIONS:

GL = GEOPANEL LINEAR

PRODUCT NOTES:

GEOLINEAR ARE AVAILABLE IN LENGTHS OF 8' OR 10' (VENEER ONLY).
SOLID WOOD ARE AVAILABLE IN LENGTHS UP TO 10', TYPICALLY SUPPLIED IN 1' INCREMENTS.

THESE ARE THE STANDARD LINEAR CONFIGURATIONS. CONTACT GEOMETRIK FOR INFORMATION
REGARDING CUSTOM SIZES.

	SKU #	BLADE SIZE
	GL-412	3-1/2" X 3/4"
	GL-434	3-1/4" X 3/4"
	GL-415	3-3/4" X 3/4"



www.geometrik.com info@geometrik.com

Description:
STANDARD
CONFIGURATIONS

Product:
GEOLINEAR CONTINUOUS

Date: JAN 2018

Drawn By: MP

Sheet No:

GL1.1

	SKU #	BLADE SIZE
<p>6" MODULE</p> <p>3/4"</p> <p>5 1/2"</p> <p>1/2"</p>	GL-612	5-1/2" X 3/4"
<p>6" MODULE</p> <p>3/4"</p> <p>5 1/4"</p> <p>3/4"</p>	GL-634	5-1/4" X 3/4"
<p>4" MODULE</p> <p>3/4"</p> <p>4 1/4"</p> <p>SHIPLAP WOOD BLADES</p>	GL-400	4-1/4" X 3/4"



www.geometrik.com info@geometrik.com

Description:
STANDARD CONFIGURATIONS

Product:
GEOLINEAR CONTINUOUS

Date: JAN 2018

Drawn By: MP

Sheet No:

GL1.2

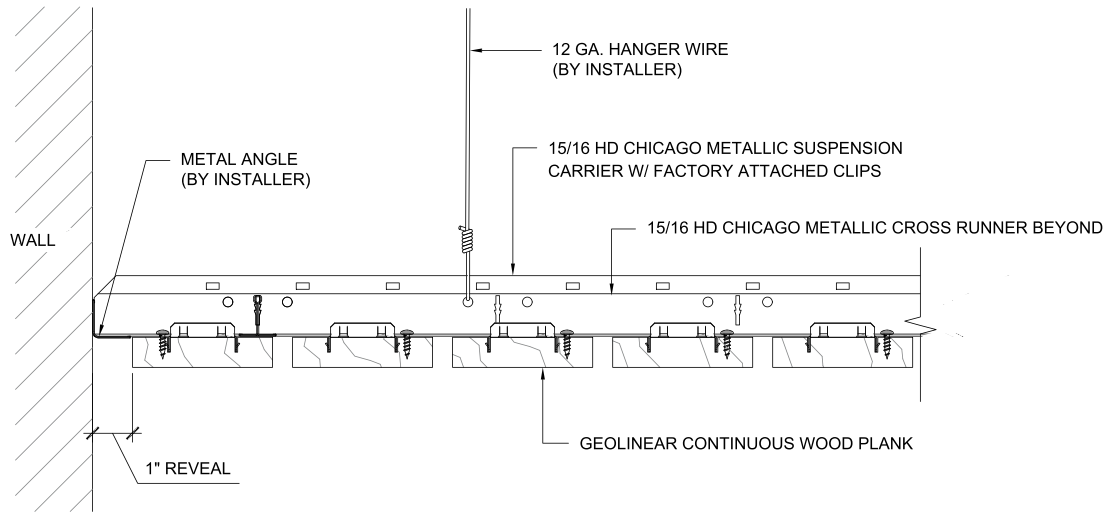
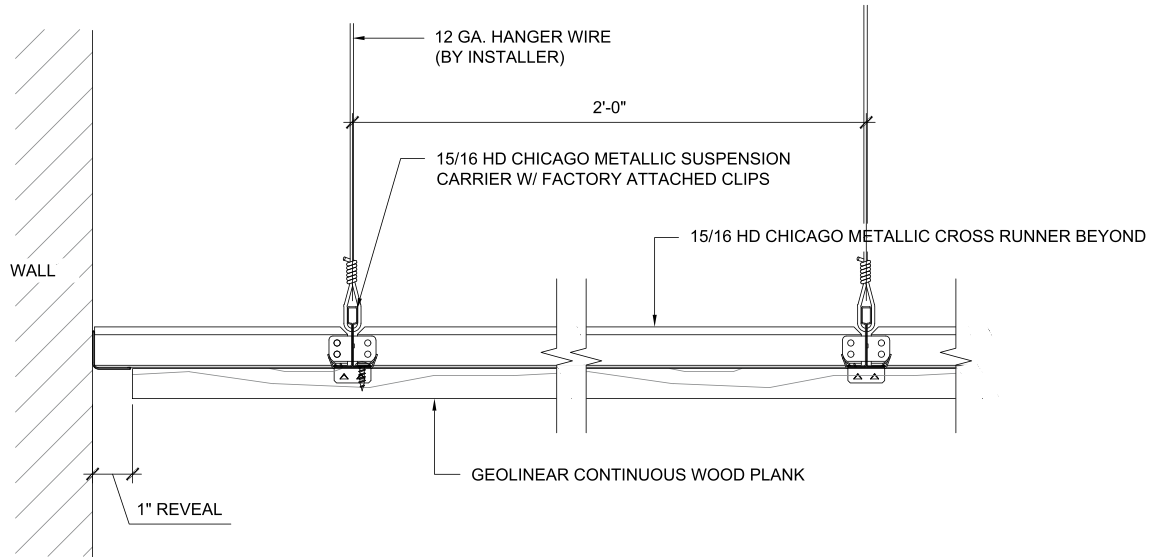

www.geometrik.com info@geometrik.com

Description:
**STANDARD
SUSPENSION**

Product:
GEOLINEAR CONTINUOUS

Date: JAN 2018

Drawn By: MP

Sheet No:

GL2.0

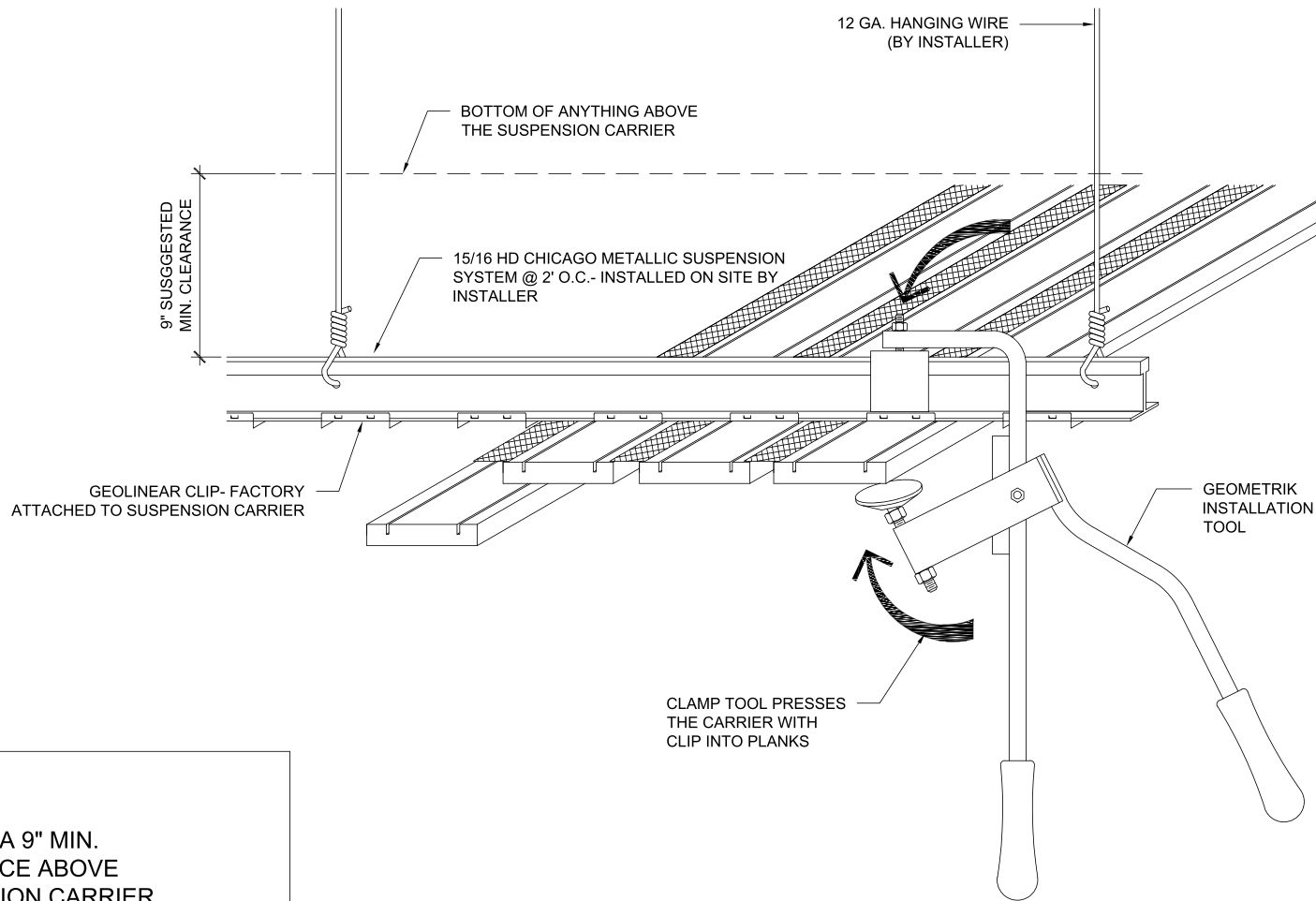

NOTE:
 PROVIDE A 9" MIN.
 CLEARANCE ABOVE
 SUSPENSION CARRIER
 TO GIVE ENOUGH
 SPACE FOR CLAMP TOOL.

GEOLINEAR



www.geometrik.com info@geometrik.com

Description:
**PANEL INSTALL
 CLAMP**

Product:
GEOLINEAR CONTINUOUS

Sheet No:

GL2.1

Date: **JAN 2018**

Drawn By: **MP**

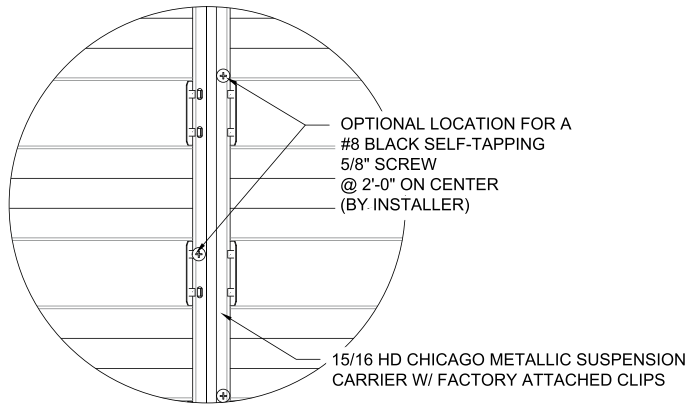

ENLARGED DETAIL - TOP VIEW

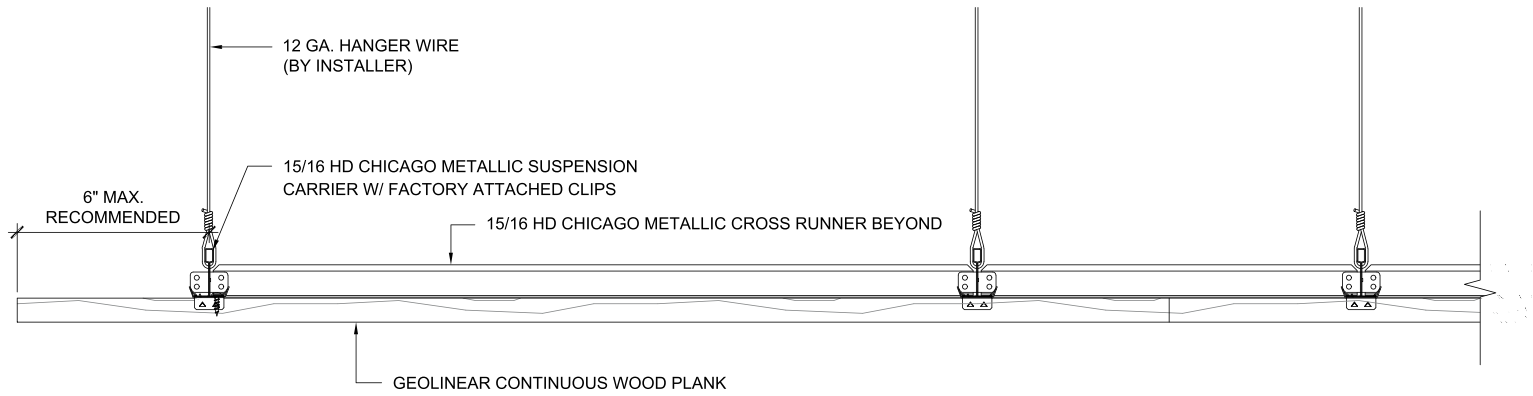

1/2" LONG SELF-TAPPING SCREW (BY INSTALLER)
 DRIVEN THROUGH GEOMETRIK SUSPENSION AT HOLE IN
 CLIP - EACH PLANK MUST BE SCREWED TO CLIP RAIL
 SYSTEM NEAREST THE JOINTS AND AT 4' O.C (MAX)

GEOLINEAR



www.geometrik.com info@geometrik.com

Description:
**INSTALLATION
 DETAILS**

Product:
GEOLINEAR CONTINUOUS

Date: JAN 2018 Drawn By: MP

Sheet No:

GL3.2

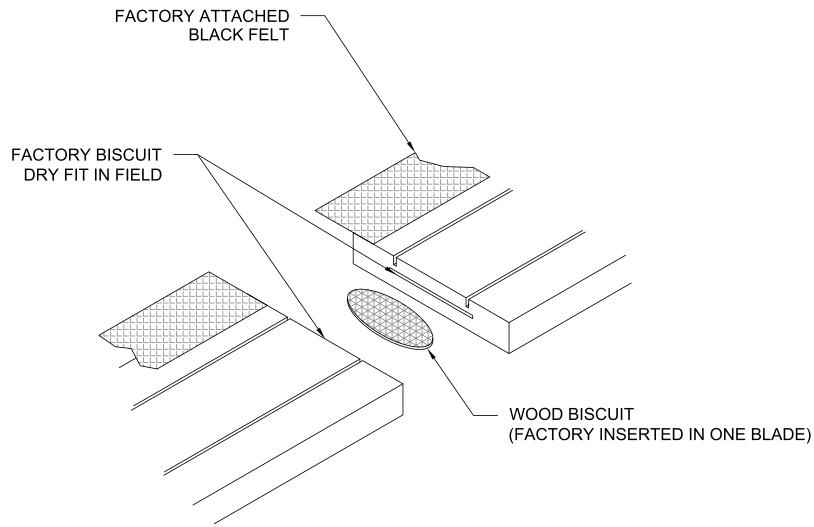

CONNECTION DETAIL
(FOR VENEERED PLANKS ONLY)

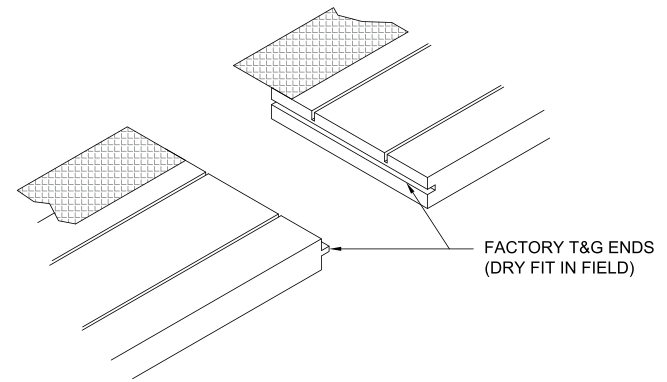

CONNECTION DETAIL
(FOR SOLID WOOD PLANKS ONLY)



www.geometrik.com info@geometrik.com

Description:
PLANK CONNECTIONS

Product:
GEOLINEAR CONTINUOUS

Date: JAN 2018

Drawn By: MP

Sheet No:

GL3.3

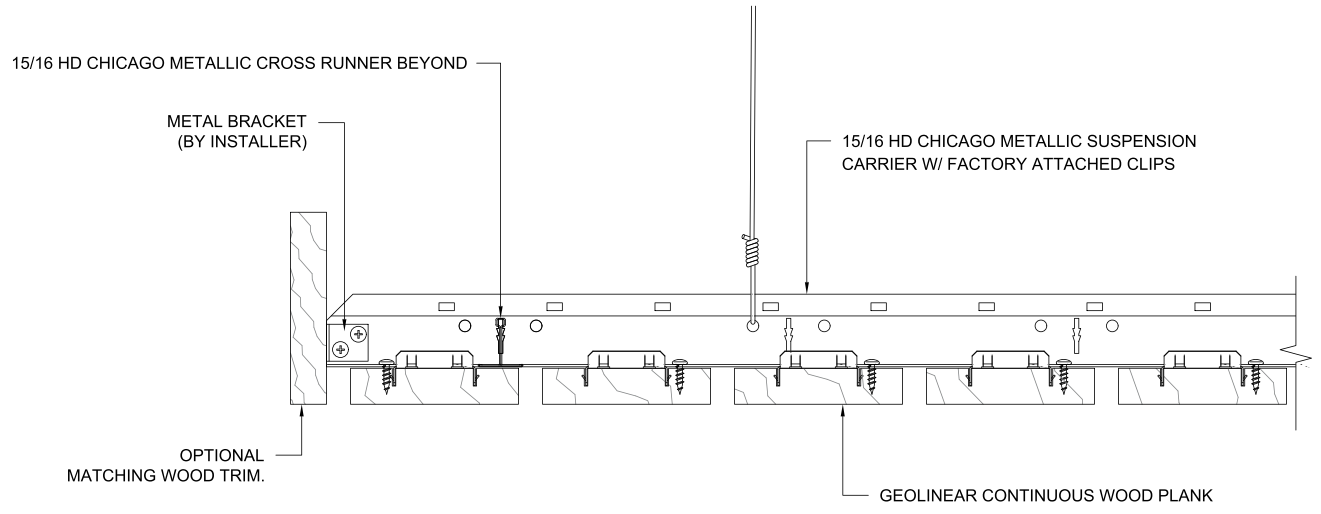

www.geometrik.com info@geometrik.com

Description:
OPTIONAL TRIM

Product:
GEOLINEAR CONTINUOUS

Date: JAN 2018

Drawn By: MP

Sheet No:

GL3.4

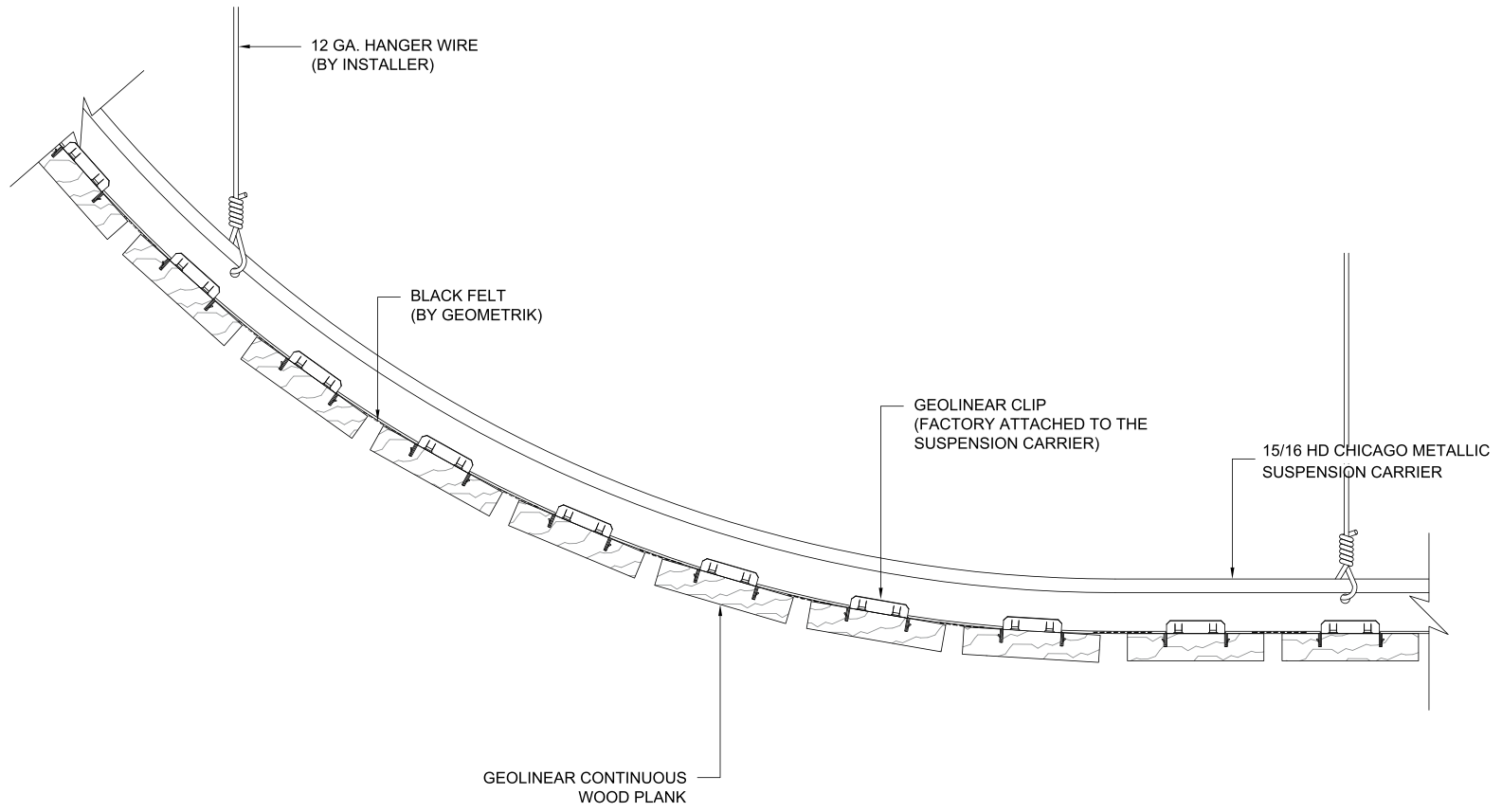

www.geometrik.com info@geometrik.com

Description:
**CURVED
TYPICAL
INSTALLATION**

Product:
GEOLINEAR CONTINUOUS

Date: JAN 2018

Drawn By: MP

Sheet No:

GL3.5

ACCESS PANEL SECTION

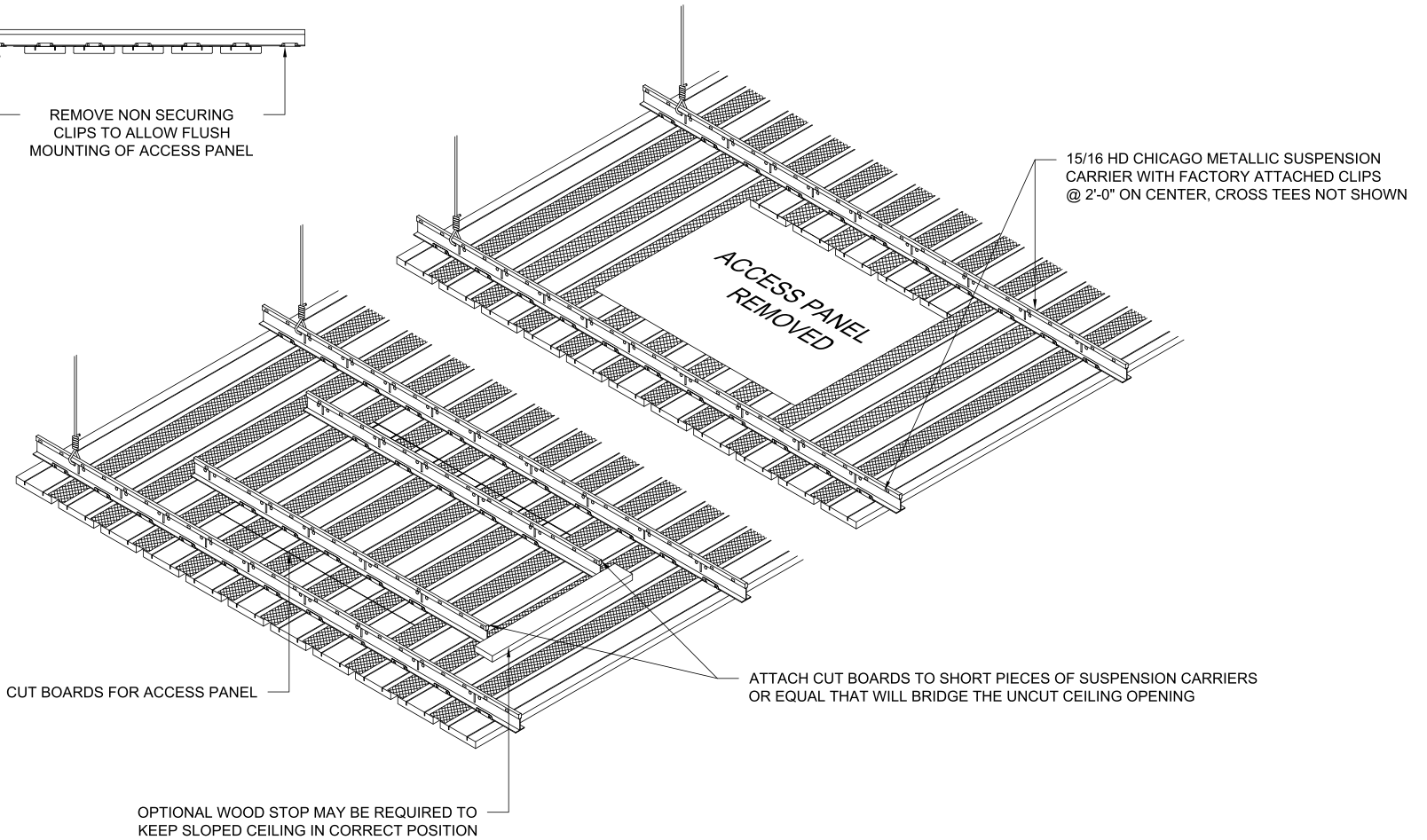
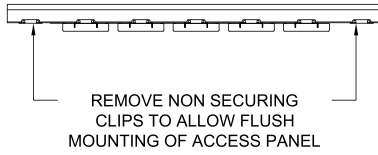

GEOLINEAR



www.geometrik.com info@geometrik.com

Description:
ACCESS PANEL
DETAILS

Product:
GEOLINEAR CONTINUOUS

Date: JAN 2018 Drawn By: MP

Sheet No:

GL5.0

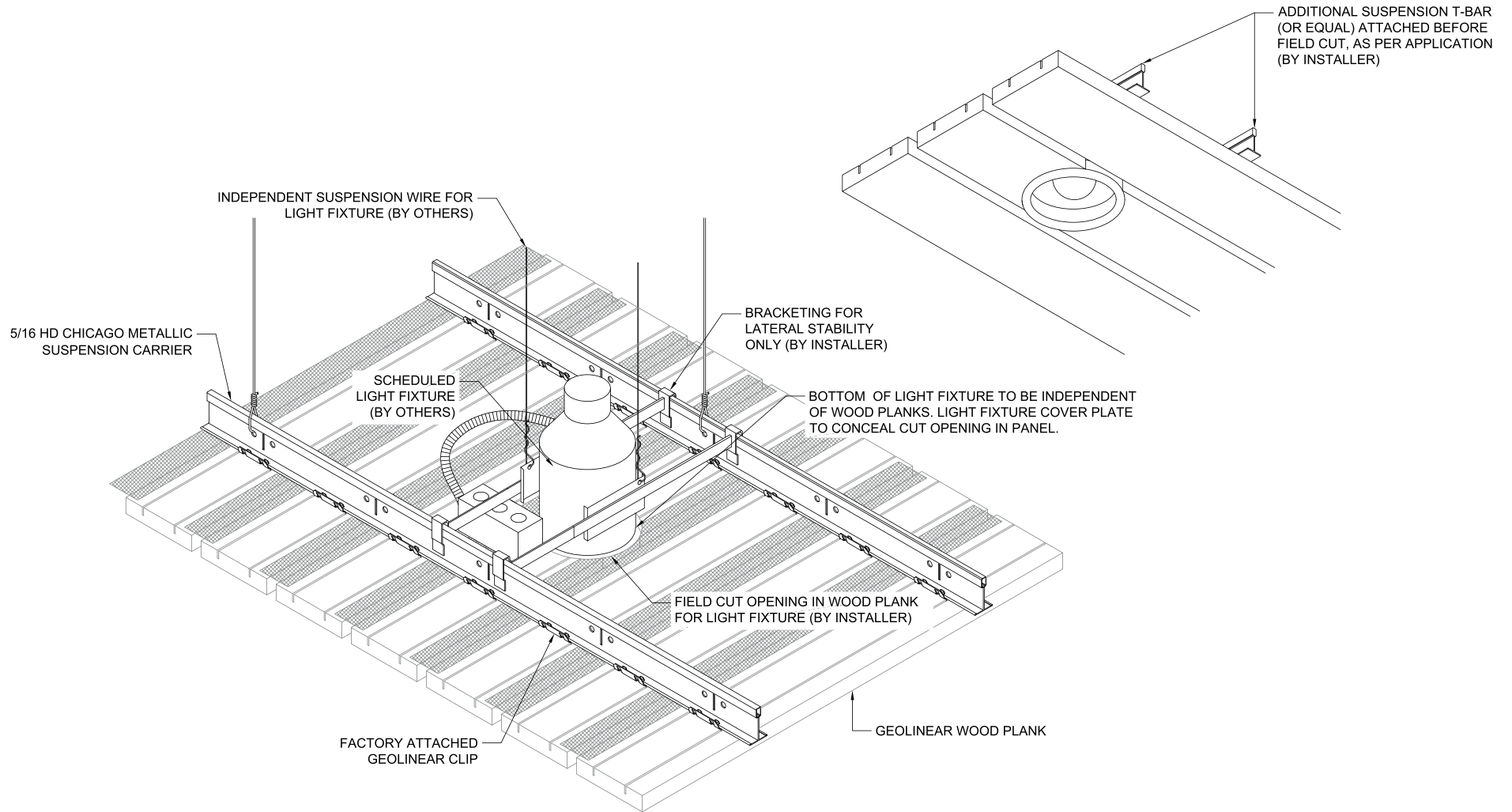

IMPORTANT:
 CUT PANELS MAY HANG UNSUPPORTED A
 MAXIMUM OF 6" FROM NEAREST T BAR CLIP.



www.geometrik.com info@geometrik.com

Description:
**POT LIGHTS
 INSTALLATION
 DETAILS**

Product:
GEOLINEAR CONTINUOUS

Date: JAN 2018

Drawn By: MP

Sheet No:

GL7.0

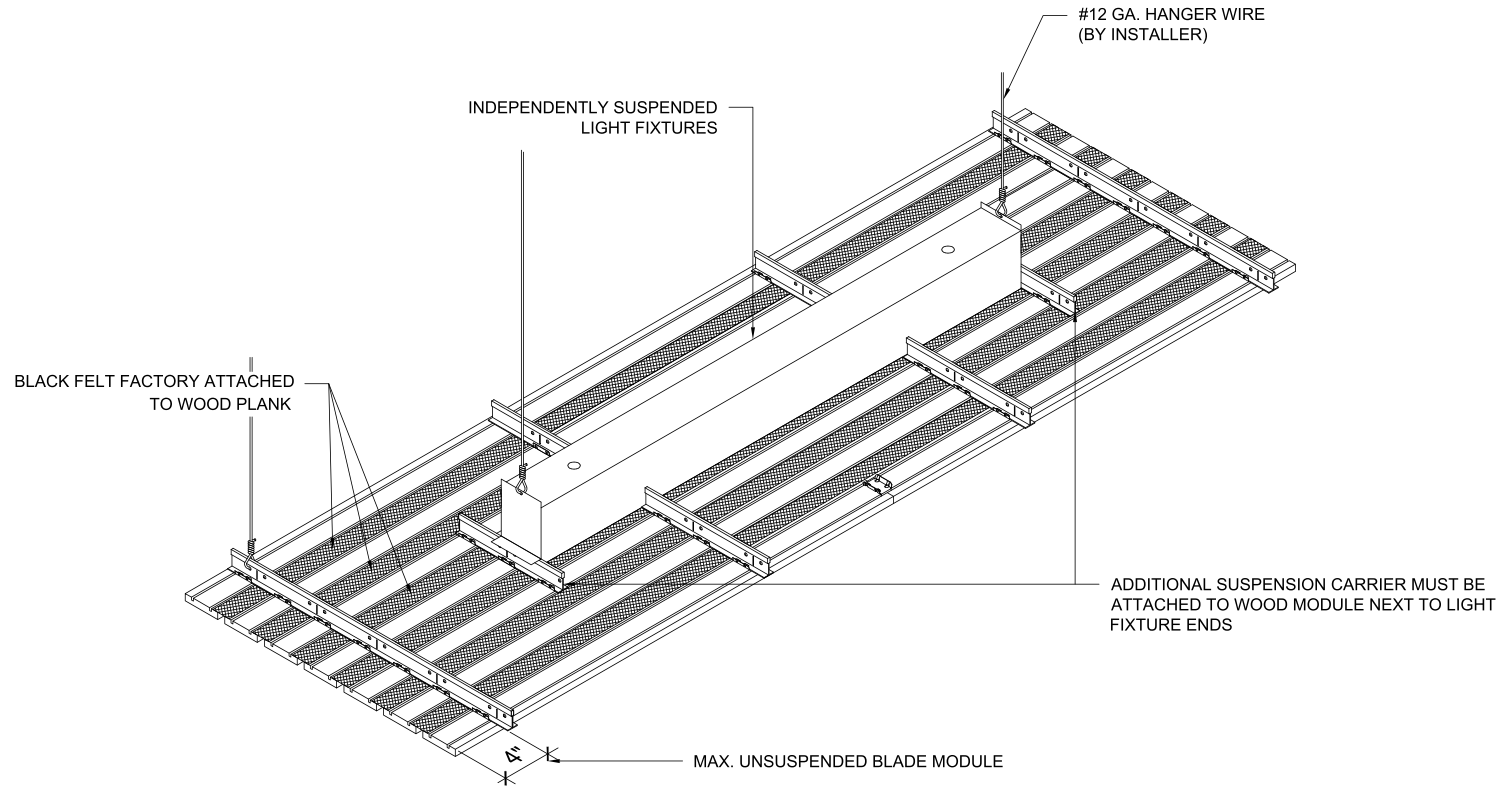

www.geometrik.com info@geometrik.com

Description:
**FLUORESCENT LIGHT
 INSTALLATION
 DETAILS**

Product:
GEOLINEAR CONTINUOUS

Date: JAN 2018

Drawn By: MP

Sheet No:

GL7.1

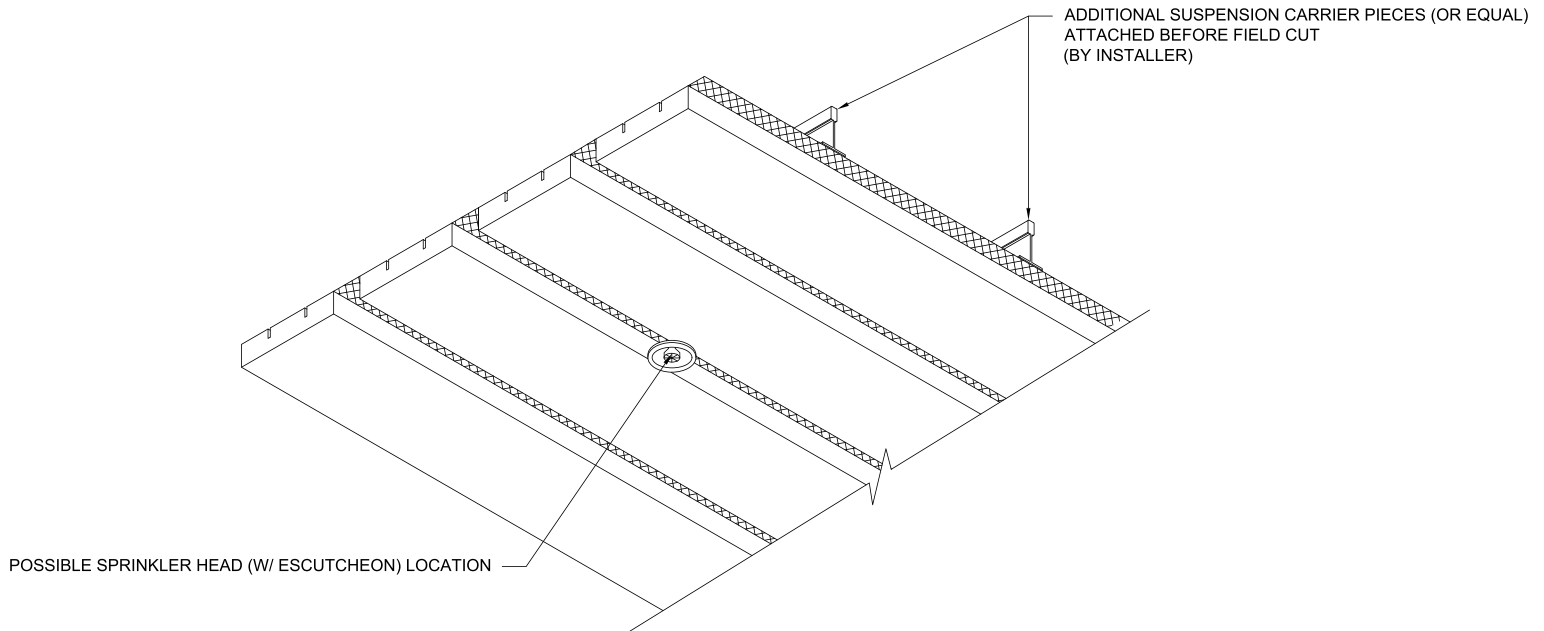

www.geometrik.com info@geometrik.com

Description:
**SPRINKLER
ISO DETAIL**

Product:
GEOLINEAR CONTINUOUS

Date: JAN 2018

Drawn By: MP

Sheet No:

GL7.2

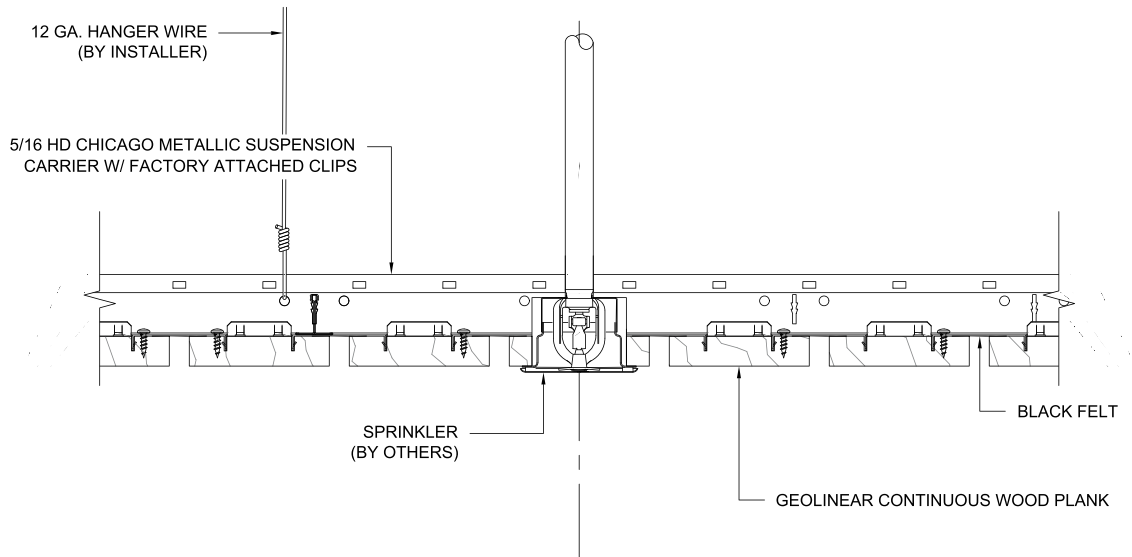

www.geometrik.com info@geometrik.com

Description:
SPRINKLER

Product:
GEOLINEAR CONTINUOUS

Sheet No:

GL7.3

Date: JAN 2018

Drawn By: MP